

iCEX-CMTM

General specs and Installation guide

1. General view

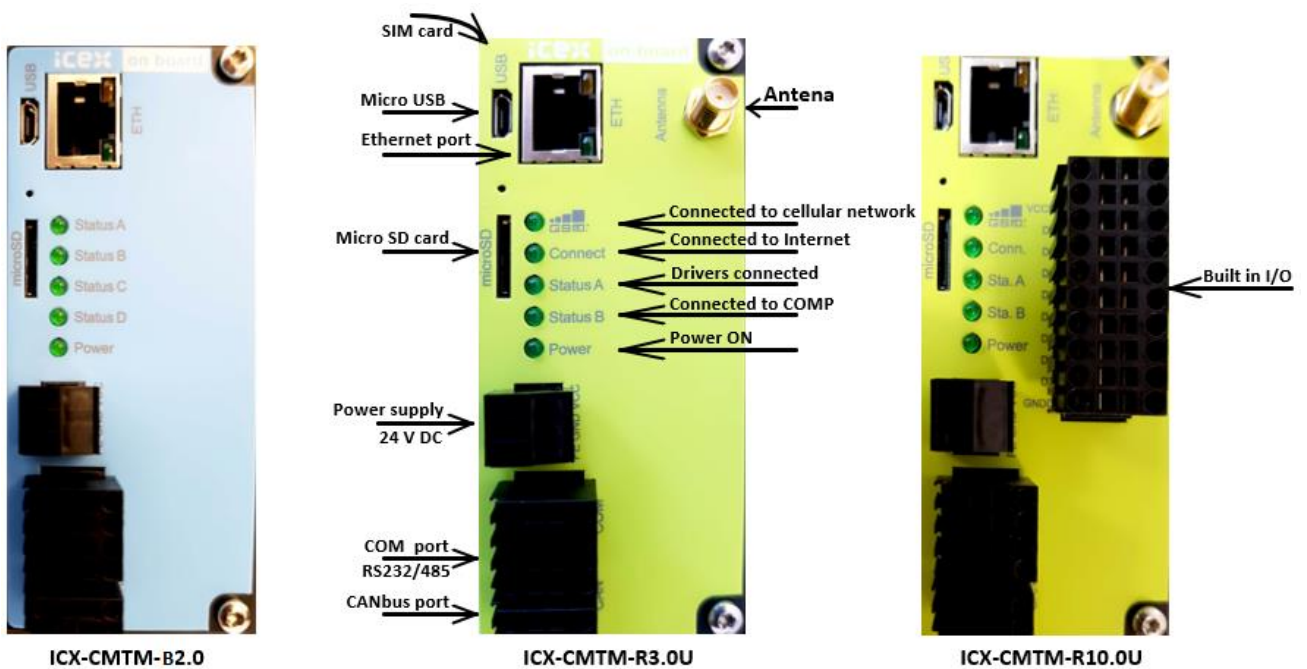

2. Specifications

2.1. Common specs:

Ethernet	1 x 10/100Base/T, RJ45 connector with traffic and link LED
Serial Interface	1 x RS232/485
USB	Micro USB port (currently not in use)
SD card	Micro SD card (currently not in use)
Operating system	IPC@CHIP® RTOS
Operating temperature	0-55 °C
Size (W x L x H)	46 x 105 x 70 mm 1.8 X 4.2 X 2.8 Inch
Mounting	35 mm DIN rail
Additional function	c/c++

2.2. Specific ICX-CMTM-B2.0 properties:

Modem	none
Status LEDs	5 (power, Status A, Status B, Status C, Status D)
CAN Interface	none
Power supply	10 – 30 V DC
Active current	Max 100 mA @ 24VDC
Analog I/O	none
Digital I/O	none

ICX-CMTM-B2.0

Typical installation

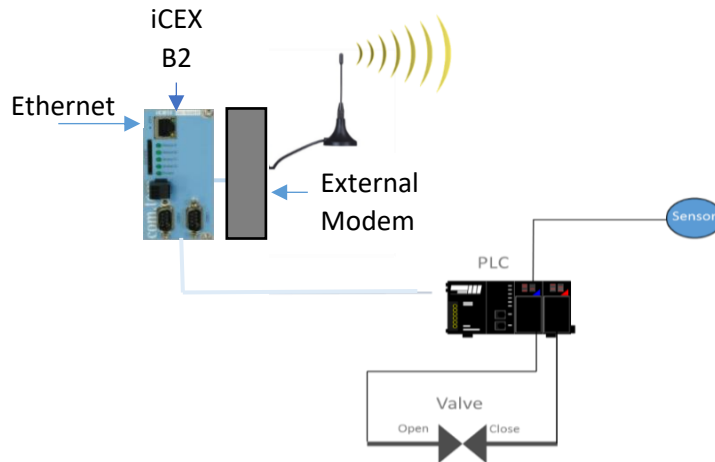

2.3. Specific ICX-CMTM-R3.0U properties:

Modem	1 x Quad band UMTS (3G) 850/900/1800/1900 MHz SIM card interface in the back
Second Serial port	None
CAN Interface	1 x CAN
Power supply	10 – 30 V DC
Active current	Max 120 mA @ 24VDC
Analog I/O	none
Digital I/O	none

ICX-CMTM-R3.0U

Typical installation

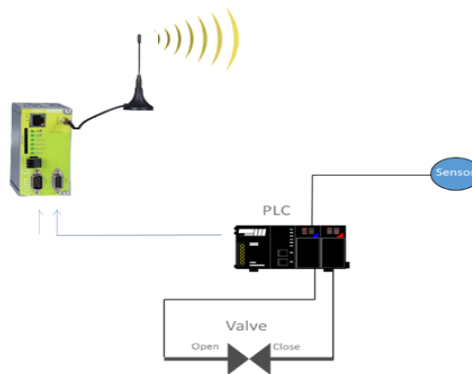

2.4. Specific ICX-CMTM-R10.U properties:

Modem	1 x Quad band UMTS (3G) 850/900/1800/1900 MHz (SIM card interface in the back)
Second Serial port	None
CAN Interface	1 x CAN
Power supply	24V DC \pm 15%
Active current	Max 280mA @ 24VDC
Analog I/O	8 x 4-20 mA or 0-10 VDC (Each one set separately)
Digital I/O	8 x Inputs (max 5mA)/ Outputs (max 500mA) @ 24VDC
Additional functions	8 x Total / Resettable counters 8 x Real Time Flow Rate

ICX-CMTM-R10.U – Typical installation

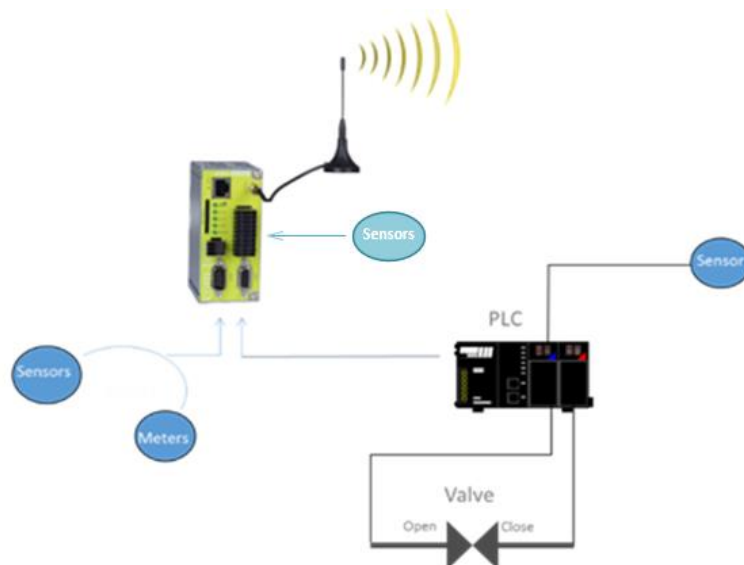

3. Power connector assignment

VCC–24VDC (+)

GND–24VDC (-)

Include circuitry to protect against reverse-polarity connections.

4. LEDs

4.1. "Power" LED

Power LED indicates iCEX power supply status.

4.2. "Status A" LED

"Status A" LED indicates the status of the connection to the monitor/control systems (drivers):

Off-The initial LED status after power up. If it remains off it indicates that the iCEX has no requests for communication with the monitor/control systems.

On-Communication OK to all monitor/control systems (drivers).

Blinking-iCEX has a communication problem with at least one of the monitor/control systems.

The LED starts blinking after three (3) unsuccessful retries.

4.3. "Status B" LED

"Status B" LED indicates the status of the communication to the RealiteQ-COMP (Central Online Management Portal).

Off–The initial LED status (after power up) is off.

On-iCEX is connected to the COMP and functioning normally.

Blinking-iCEX has a communication problem with the server.

4.4. "GSM" LED

"GSM" LED indicates the status of the cellular modem connection to the cellular operator

Off – The initial LED status (after power up) is off.

On – The modem is power-on and connected to the Cellular network.

Blinking - connection to the Cellular network (GSM) in progress.

4.5. "Connect" LED

"Connect" LED indicates the status of the cellular modem connection to the Internet.

Off–The initial LED status (after power up) is off.

On–The modem is connected to the Internet and functioning normally.

Blinking–The modem is in sign-in and connection procedures. "GSM" LED indicates the status of the cellular modem connection to the cellular operator

Off–The initial LED status (after power up) is off.

On–The modem is power-on and connected to the Cellular network.

5. SD card

Currently not used.

6. Communication Ports

6.1. 10/100BaseT connection

Standard 10/100BaseT RJ45 connector with 2 status LEDs:

Yellow LED -Activity status: **On**-activity, **Off**-no activity. On in normal operation.

Green LED -Link status: **On** –link on, **Off**-no link. Blinking in normal operation.

6.2. RS232/485 combined interface

Combined RS232/RS485 interface. The COM interface can be used alternatively as RS232 or RS485. A suitable cable should be used for the selected interface. The RS485/RS232 interface is not galvanic isolated. The Baud rate for both functions (RS 232and RS 485) is up to 250 Kbit/s and cannot be modified. The RS485 interface is setup for half duplex operation. Pull-up, pull-down and termination resistors for the RS485 interface are recommended in the connection cable.

6.1.2. Communication pin assignment:

Connector COM Pin Out	Function RS232
Pin 1	GND
Pin 2	
Pin 4	Tx
Pin 6	RTS
Pin 8	Rx

Table 3.1: Pin Configuration RS232

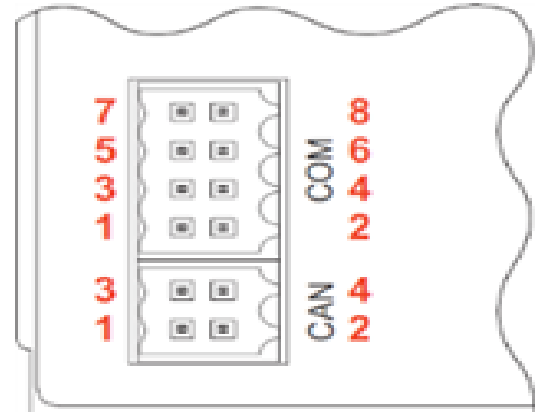

Connector COM Pin Out	Function RS485
Pin 3	B (+/Z)
Pin 5	A (-/Y)
Pin 7	Termination B

Table 3.2: Pin Configuration RS485

Note: ICX-CMTM units have built in 120 Ohm Termination resistor. Termination must be activated if the unit is at the end of network (end of RS485 cable). To activate Termination, bridge between Pin 5 – A (-/Y) and Pin 7 (Termination).

6.1.3. Example of RS232 connection:

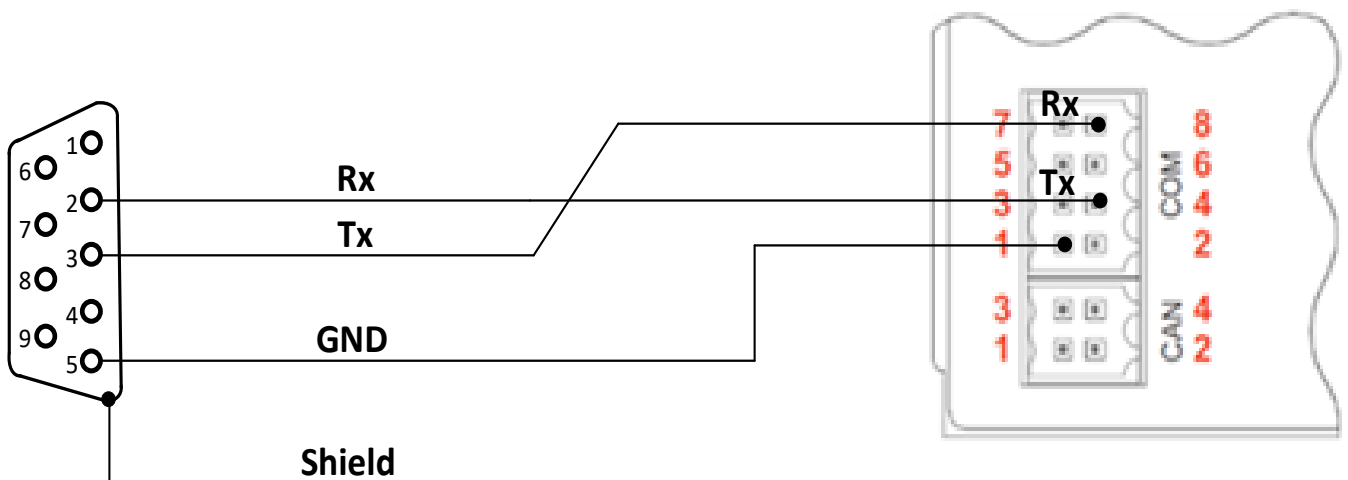

Example of RS485 connection:

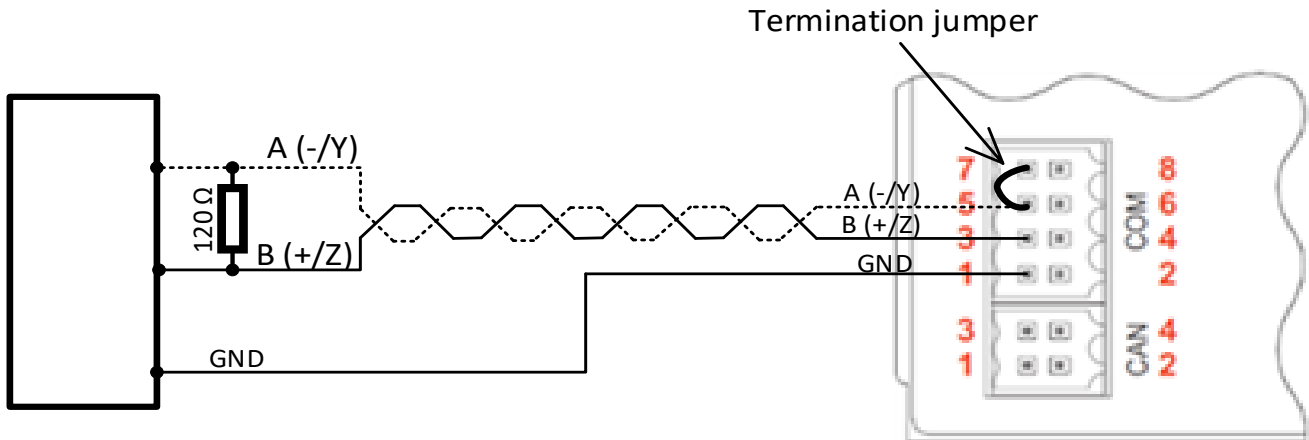

6.3. CAN port

Currently not used.

6.4. Micro USB port

Currently not used.

7. Button

Internal button to restoring factory settings. Externally accessible with a pointed object such as a straightened-out paper clip.

8. RTC

Real-time clock. It is powered with high capacity capacitor. The clock can continue to run up 3 weeks without external power. iCEX synchronizes the RTC time with the server on power up and every 24 hours.

9. I/O

iCEX model R10.U with I/O has 8 analogs input current / voltage and 8 discrete 24 volt DC input / output.

9.1. I/O pin assignment:

PIN	Description	Description	PIN
D-VCC	Power Supply for Digital I/O	Analog In 0	A0
D0	Digital I/O 0	Analog In 1	A1
D1	Digital I/O 1	Analog In 2	A2
D2	Digital I/O 2	Analog In 3	A3
D3	Digital I/O 3	GND for Analog In	A-GND
D4	Digital I/O 4	Analog In 4	A4
D5	Digital I/O 5	Analog In 5	A5
D6	Digital I/O 6	Analog In 6	A6
D7	Digital I/O 7	Analog In 7	A7
D-GND	GND for Digital I/O	GND for Analog In	A-GND

9.2. Analog inputs in detail:

“GND for Analog In” is galvanic isolated from “GND for Digital I/O”. The Analog I/O signals are not galvanic isolated among themselves.

Technical data:

Analog Inputs: voltage input 0-10.1V or current input 0-25mA. Any analog input can be used as a voltage input or current input.

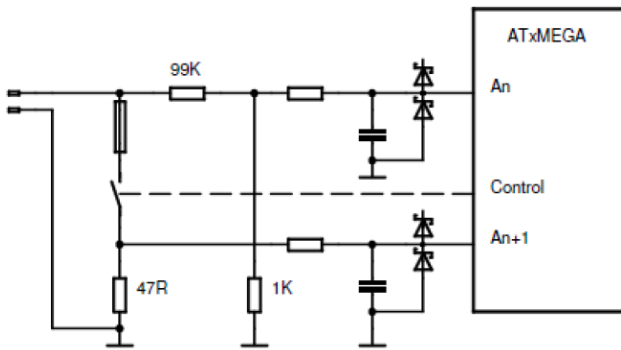

Analog input A/D is 11 bits. The whole range is 0 – 2047.

9.3. Digital I/O in detail:

Digital I/O x can be used as an input or output. By using as an output, the signal status can be read back via the input function. In both applications, the signals refer to "GND for digital I/O" which is galvanic isolated from "GND for analog in". The digital I/O x signals are not galvanic isolated among themselves.

Technical data:

Digital Inputs: Sink, 24 V DC type 5 mA;

The nominal value for TRUE: 15 V DC min

The nominal value for FALSE: 5 V DC max

Digital Outputs: Transistor, 24 V DC, max 500 mA

Short-circuit and overload resistant.

