

Case Study 14 – SCADA and security in Natural Gas infrastructure

Project Description:

RealiteQ is a virtual ICT network that opens a reliable, redundant, safe and secure event channel for real time remote control, monitoring and crisis management. It facilitates real time monitoring, control, and data acquisition from remote systems that are distributed at various locations and different networks worldwide.

The easy-to-install and user-friendly philosophy of the RealiteQ system have been applied to advanced control, so management and maintenance people can tackle large, interactive process problems. Users can now easily optimize their system for maximum throughput, maximum profit and minimum energy.

Realite Technologies with its RealiteQ platform offers communication solutions for remote monitoring and control of oil & gas facilities.

Whether the process is drilling, refining, filtering, PRS, PRMS, city gate or other, RealiteQ is the perfect technology for remote control and monitoring.

With RealiteQ, you have a reliable and cost-effective solution for monitoring gas well production, pipeline flow, distribution system pressures and more...

Case Study 14 – SCADA and security in Natural Gas infrastructure

Project Description cont.:

The gas flows through the national transmission system, and after an additional pressure reduction, it is transferred to the distribution companies.

Our project extends across the north of the State of Israel.

As part of the project, the control, security and SCADA systems are implemented in about 160 facilities in total.

About 10 facilities are PRS / PRMS or THT addition (for adding smell to the gas), while others are installed in factory yards or other large consumers facilities.

The components of the control panels at the various facilities include:

- Programmed controller
- Flow corrector
- iCex (Integrated Cellular & Ethernet Explorer)
- Security cameras
- Perimeter fence sensing system
- Power supply & backup batteries

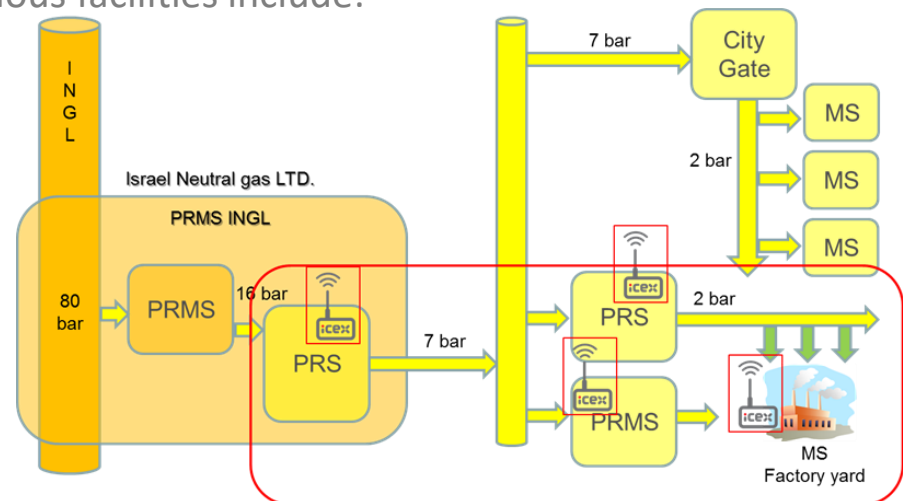

Case Study 14 – SCADA and security in Natural Gas infrastructure

Project Description cont.:

It is important to note that the iCex component, as part of the RealiteQ system, makes communication to the cloud very stable, reliable and secured.

Workstations at the Control Center allow system operators remote control of all installations and sites. The monitoring and measurement data of the gas supplied is routinely transferred to the national gas company through a secured channel for billing.

In times of emergency, the gas supply can be stopped from the control center by typing a designated password and pressing the closing key of the dedicated facility where the event takes place.

In the definition of regulation, it was determined that renewing the supply of gas requires reaching the site, and only from this it is possible to carry out a process of resetting and opening the supply plant.

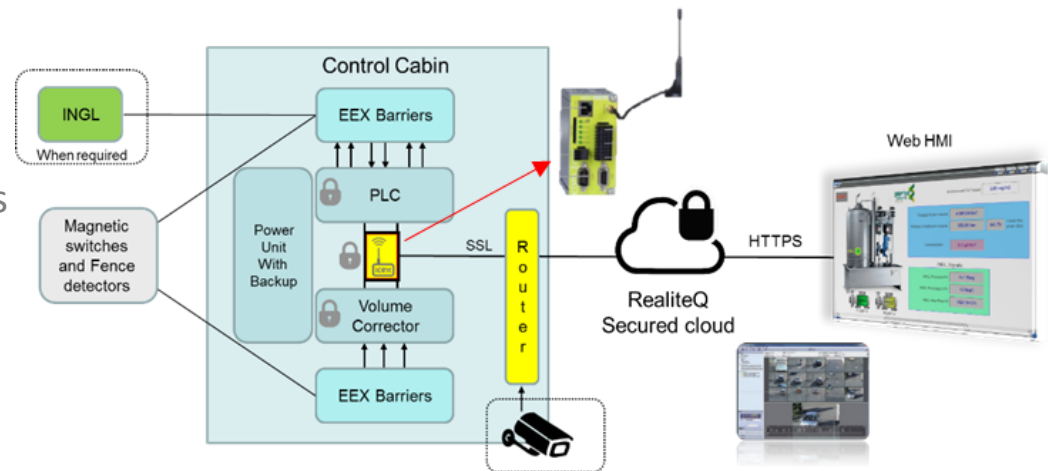

Unique Capabilities:

RealiteQ was chosen to provide the solution for real-time monitoring and remote control of Natural Gas distribution system in the north of Israel. The natural gas network is part of the national plan of moving the industry to use clean energy.

RealiteQ Platform was selected as for the combination of several unique advantages:

- Most advanced End-to-End, Real time cloud-based SCADA solution.
- High system reliability
- Secured web system
- Real time system which allows to monitor and remotely control (close valves) crises and other events
- Technological flexibility, including the ability to communicate easily with different 3rd party technologies Moreover, it's very competitive cost together with the fast and simple installation makes RealiteQ the most cost-effective option in this case.

Case Study 14 – SCADA and security in Natural Gas infrastructure

Summary and Results:

RealiteQ has enabled the customer to install facilities in an efficient, economical and secured manner without the need to invest large sums in expensive communications and computer infrastructure.

Because RealiteQ is a modern and advanced cloud system, it enables the transmission company to develop at a pace that is suitable for market growth.

RealiteQ saves customers a lot of Money and allows them to control their expenses on the one hand, and provide their customers and regulation authority's with excellent service on the other.

