

You can afford the Best

RealiteQ™

New Generation of SCADA & Remote control solutions

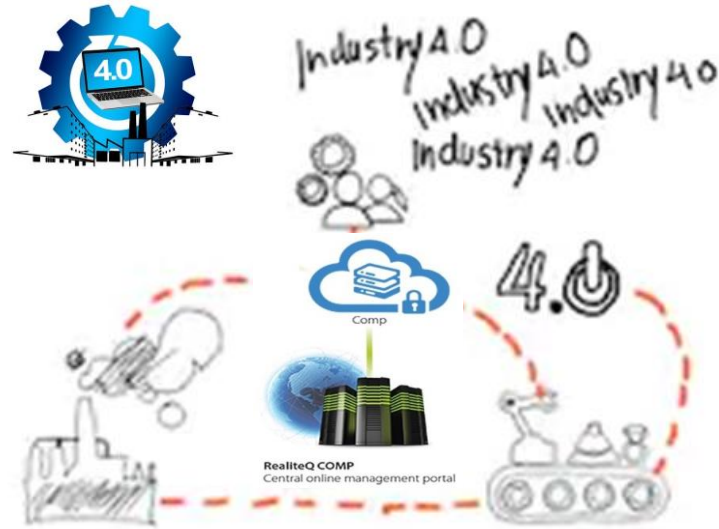

SMART INDUSTRY CASE STUDY

**IIOT & CLOUD-BASED, REAL-TIME REMOTE CONTROL
OPERATIONAL & DATA MANAGEMENT SOLUTION**

RealiteQ is an IIoT & Cloud based Holistic solution software and hardware solutions from the infrastructure level (communication) up to the ICT and SCADA systems level for real time, remote-control operation & Data management

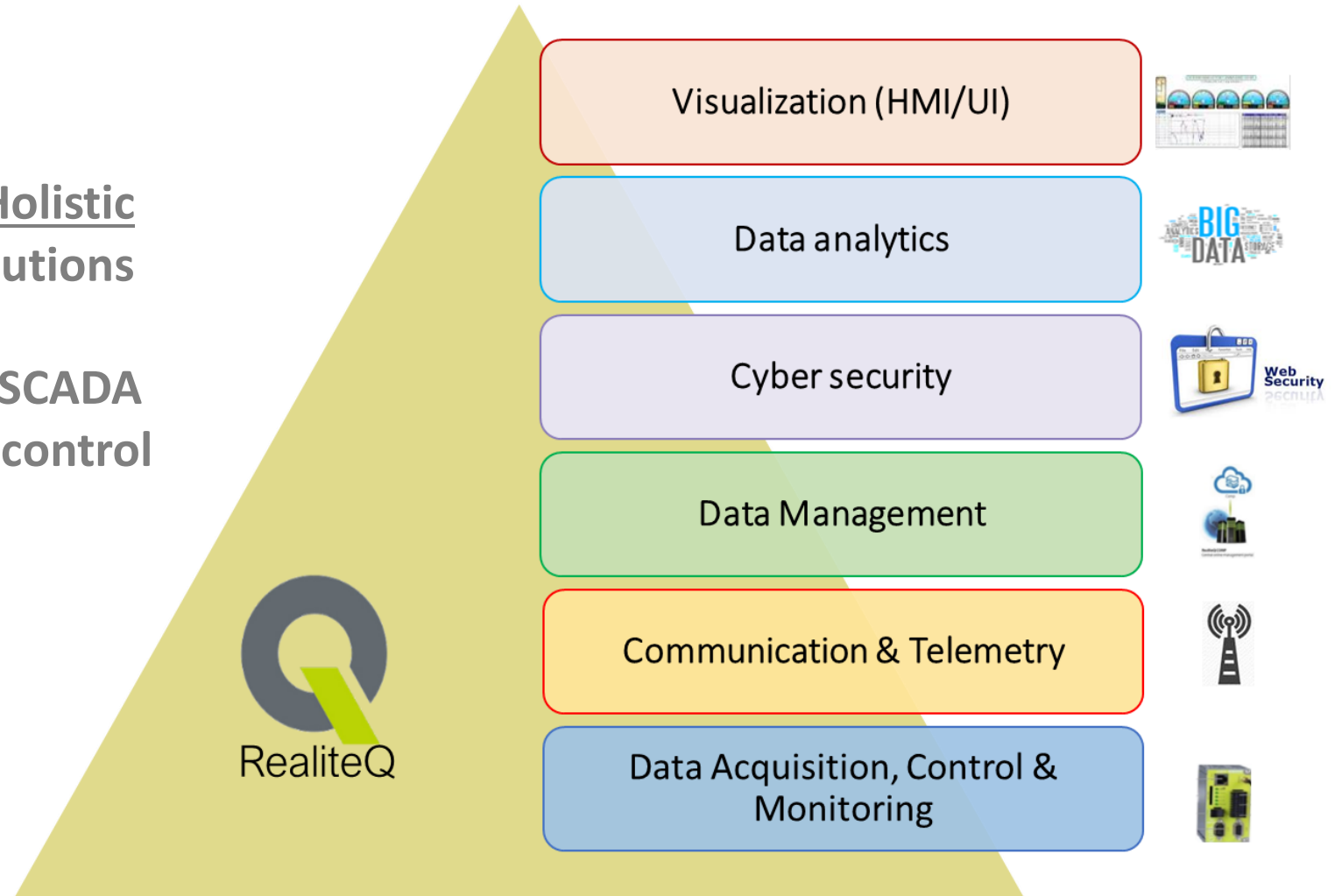

RealiteQ Provides integral IT-OT convergence Offering significant benefits along the main strategy operative dimensions: Costs, Quality, Speed, Reliability & Security



Why RealiteQ?

Because it's:

- **Smart**
- **Simple**
- **Affordable**

There are 3 main barriers when adopting Digital Transformation

Cost – Technology complexity - security

RealiteQ eliminates these 3 barriers

- **Cost** - RealiteQ installation and maintenance costs are affordable and fit any budget.
- **Technological complexity** - RealiteQ requires simple, fast & non-distractive installation, No special IT infrastructure or capabilities are required, it's maintenance free & and easy to use.
- **Security Risks** - RealiteQ is a highly secure system. It has been “Designed for Cyber” with many cyber security and operational safety components.

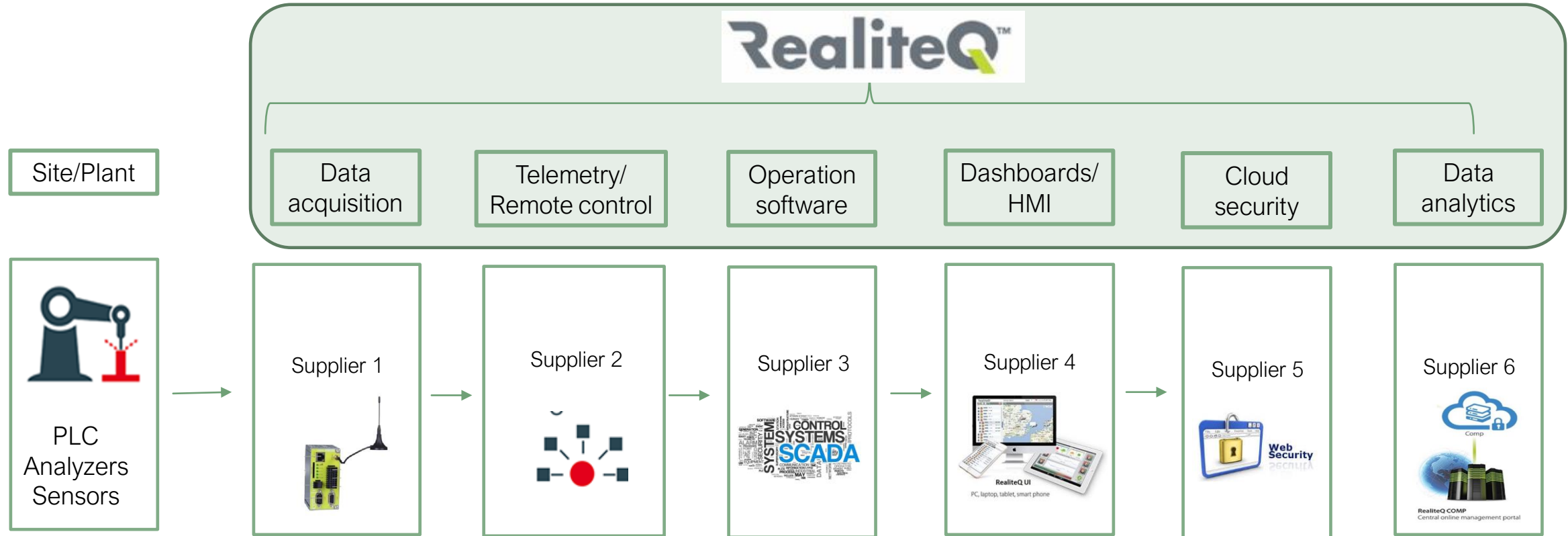



Integrates information technology (IT) with operational technology (OT) and offer significant benefits along the main strategy operative dimensions:

- Costs
- Quality
- Speed
- Reliability & security

IT/OT CONVERGENCE

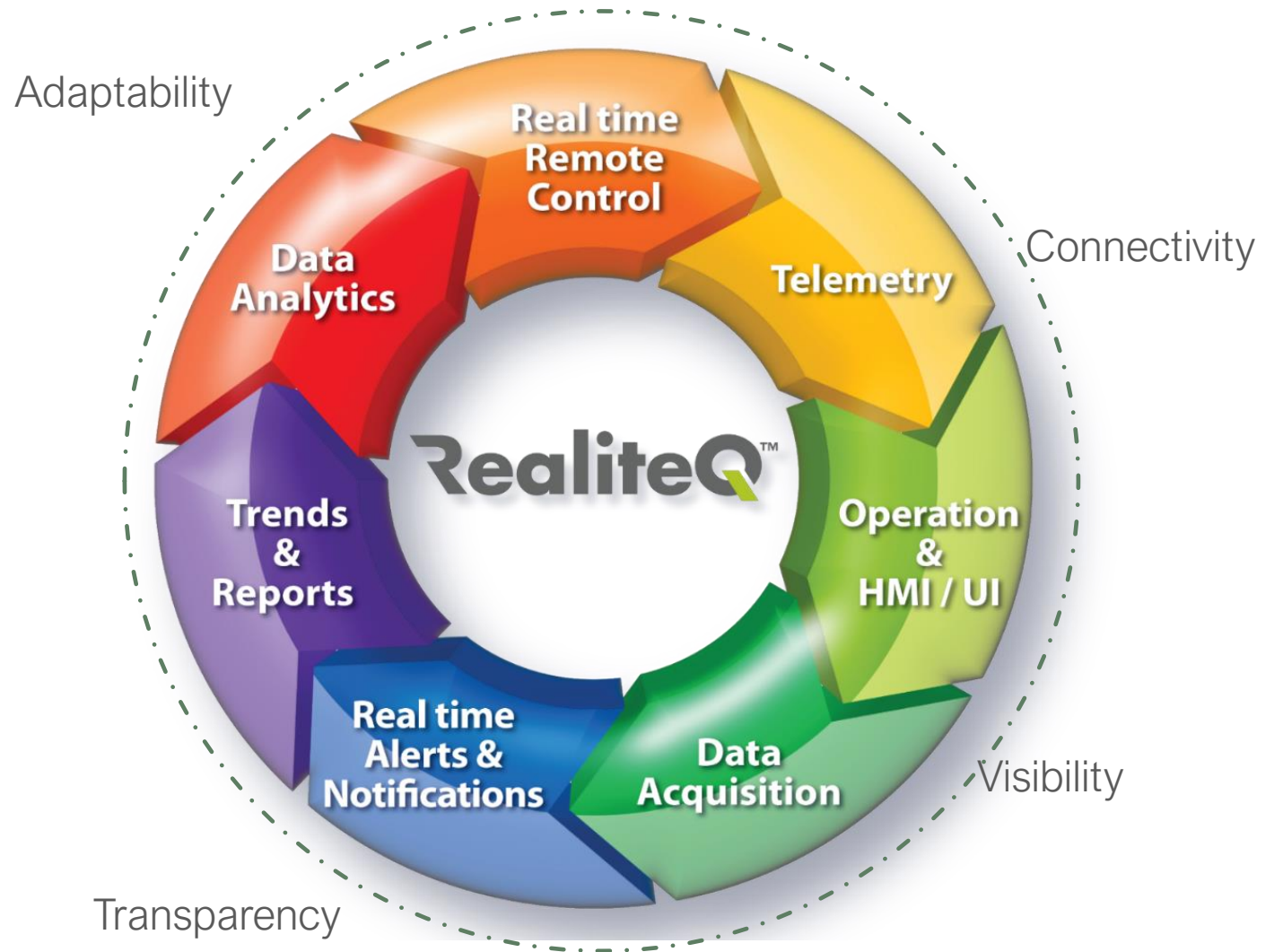



The Bridge to smart industry

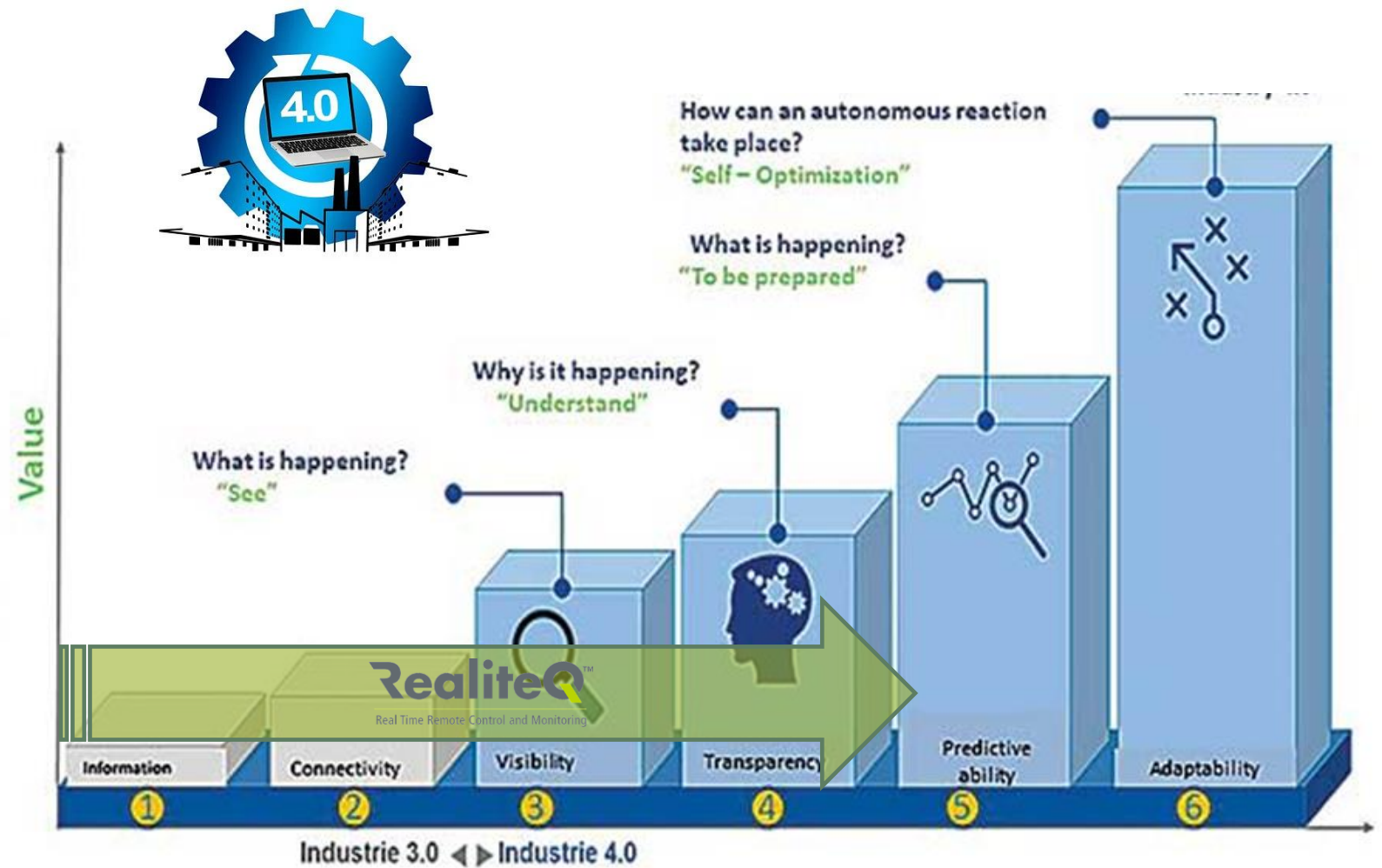

From data acquisition to data analytics

- An Israeli leading company and one of the leaders worldwide. The company is developing, producing & marketing solutions in 3 main areas: Self- adhesive, Lamination and Coating.
- The plant, which operates in three shifts in the policy of 24/7/365, is recognized as a leading supplier in its field.



- The plant managers want to implement a solution for collecting data from the production floor and processing it to an existing external BI system.
- All the equipment in the plant including main production lines as well as peripheral equipment were connected.



Production lines

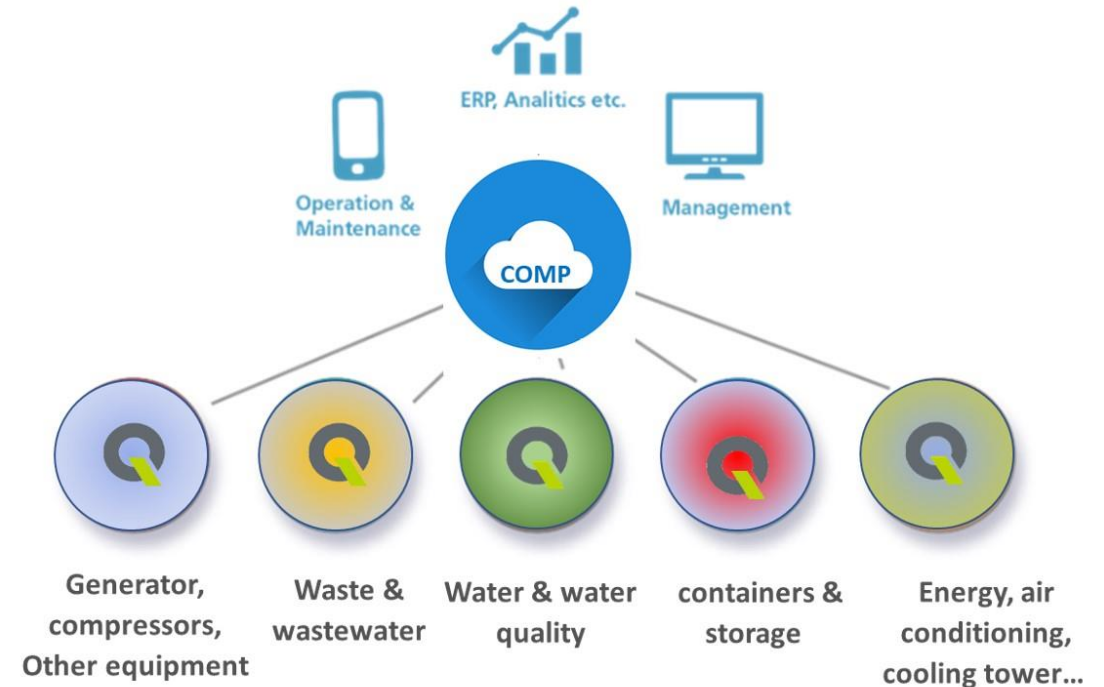

Peripheral Equipment

- Seamless interfacing with existing equipment, software and old SCADA
- Support main industrial communication protocols
- Fast, simple & undistributed installation
- Simple to use & maintain
- Can be connected directly & in parallel to PLCs, sensors and analyzers with different communication protocols
- Built in graphical editor for customized dashboards, trends, table, Reports...

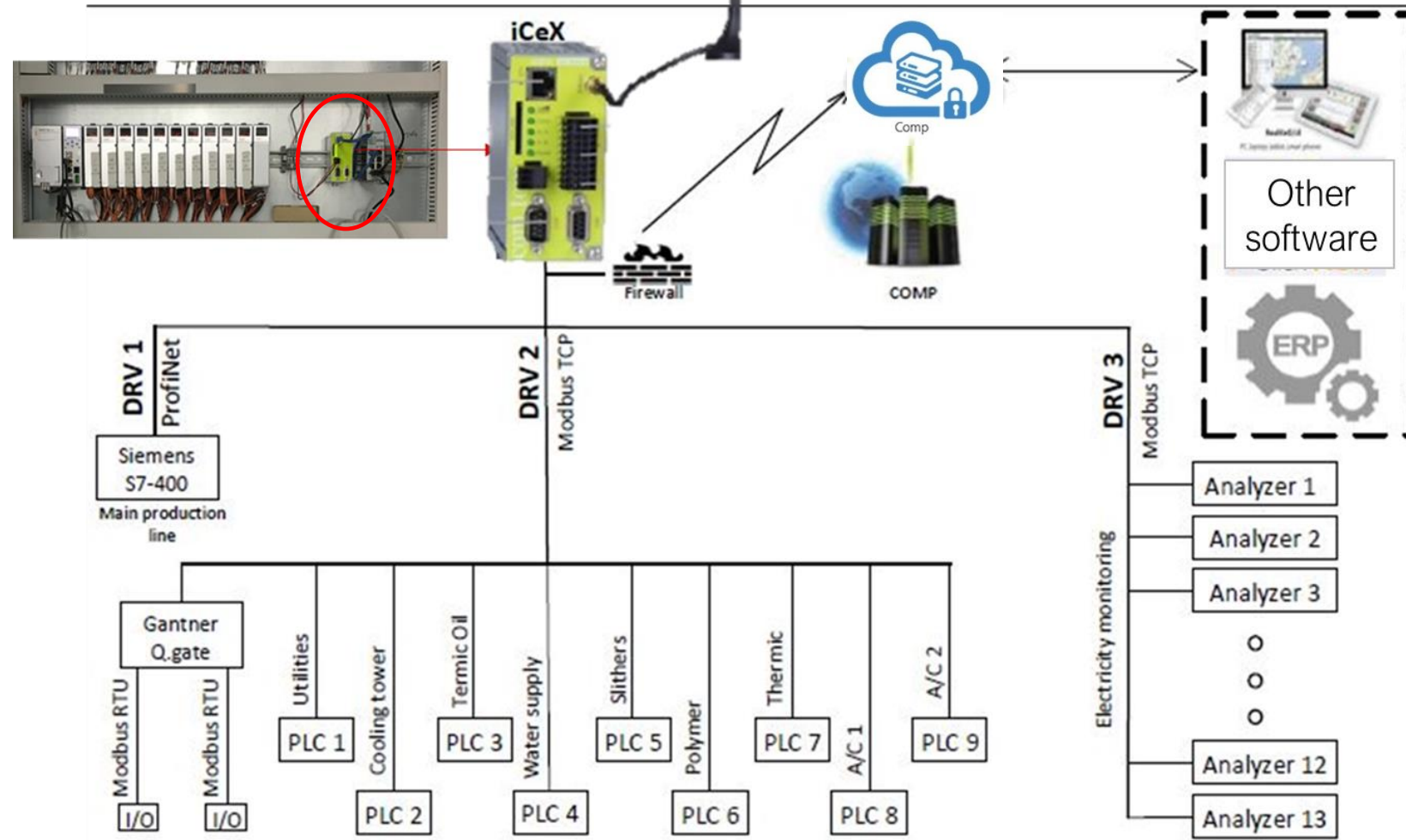

Managers, engineers and technical staff can see the operation screens, trend in graphs, and customized reports

Also, they get alerts in real time 24/7 the entire system from any were any time using any device they have connected to the internet. They

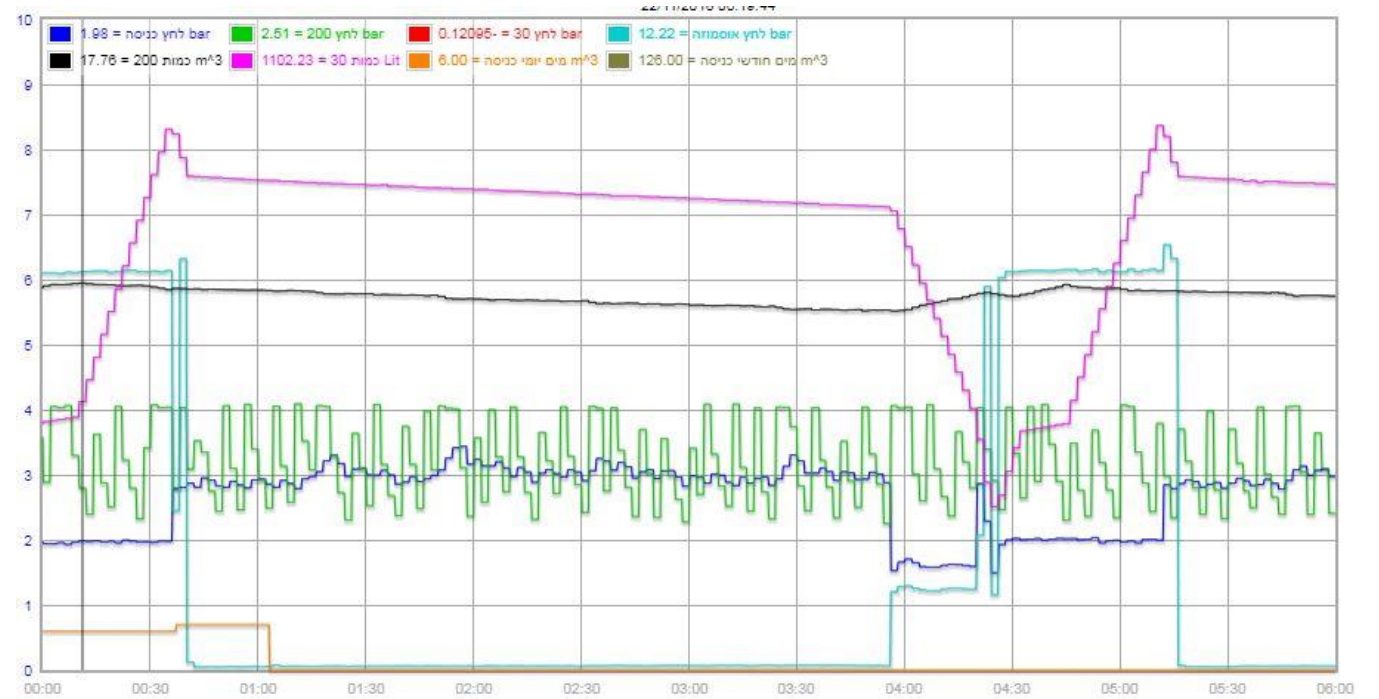

value: Quality: Unknown Stamp: 05/03/2018 14:03:18
Current alarms : 2 active alarm

Path	Tagname	Description	State	Start	End
/nirotek02/alarms/alarm2012	התרעת לחץ מים קרים 15 למכונות	לחץ נמוך 15 מעלות למכונות	unacknowledged	02/11/2018 18:44:25	17/11/2018 19:00:06
/nirotek02/alarms/low_prs_30 micron	לחץ מים 30 מיקרון	התרעת לחץ נמוך 30 מיקרון	active	13/11/2018 14:54:05	

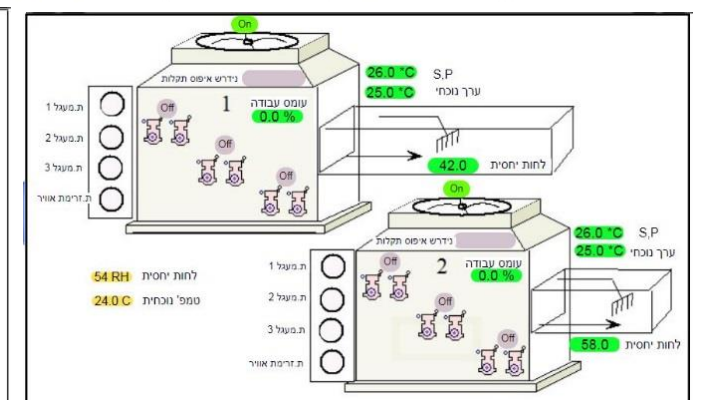
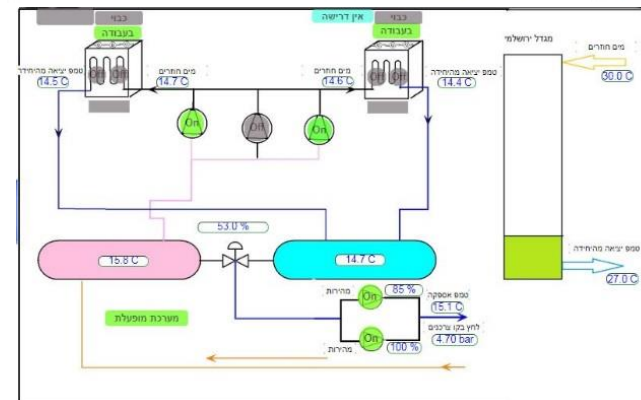

Reduce risks

Risk of ignorance

Not knowing in Real time what is going on

Risk of ignoring

Ignoring existing and future problems

Risk of late response

Late response to ongoing problems and crisis events

Increase Efficiency & Safety

INCREASING COORDINATION

INCREASING COLLABORATION

INCREASING DATA SHARING

COVID 19 – will change the way we work for ever

RealiteQ makes this change simple and affordable – by allowing secured remote operation by anyone (authorized) from anywhere (including home), anytime using any device connected to the Internet (PC, Laptop, Tablet, Smartphone) with no need to install any software or application.

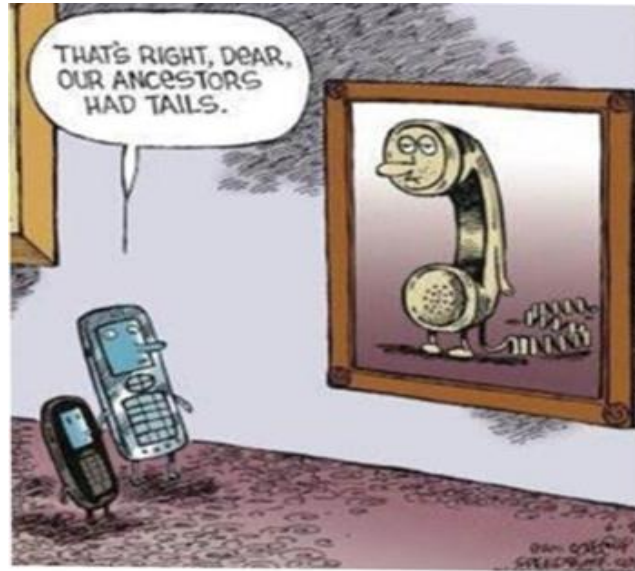

Technology should be the solution not the problem!

For more
information
Please contact

Reali Technologies LTD.
realinfo@RealiteQ.com
www.RealiteQ.com

You can afford the Best
RealiteQ™
New Generation of SCADA & Remote control solutions

Realitech | 4.0

SMART INDUSTRY
SMART - SIMPLE - AFFORDABLE